



SUMMERHILL
Commercial Real Estate, LLC

FOR LEASE
BELLBOY WEST
7204 27th Street West
St. Louis Park, MN 55426



OFFICE SPACE FOR LEASE:

- Suite 106:* 306 rentable sf, \$390/month total
- Suite 207:* 314 rentable sf, \$350/month total
- Suite 205:* 318 rentable sf, \$390/month total
- Suite 227:* 323 rentable sf, \$410/month total
- Suite 214:* 600 rentable sf, \$750/month total
- Suite 220:* 955 rentable sf, \$1,175/month total
- Suite 221:* 1,036 rentable sf, \$1,275/month total

WAREHOUSE SPACE FOR LEASE:

Warehouse: 2,590 sf (additional possible), \$2,275/month includes utilities, 18' clear, drive in door/truck high dock access

- Very nice newer office finishes in a well maintained building.
- Located across the street from the post office.
- Prominent, easy to find, location.
- Very economical rates, ample parking.
- Convenient central location near many amenities.
- Local, responsive, ownership and management.

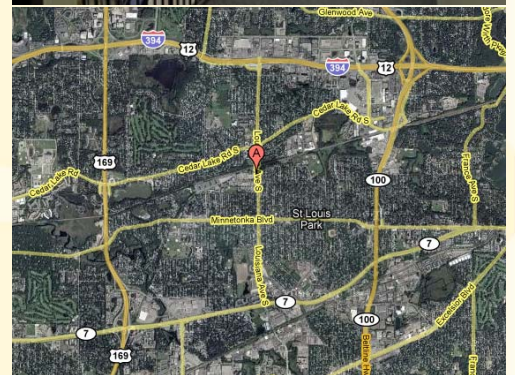

For more information call:
Peter Kordonowy

952.556.5151

or visit our website at:
www.summerhillcommercial.com



SUMMERHILL
Commercial Real Estate, LLC

FOR LEASE
BELLBOY WEST
7204 27th Street West
St. Louis Park, MN 55426

Suite 106, 306 RSF

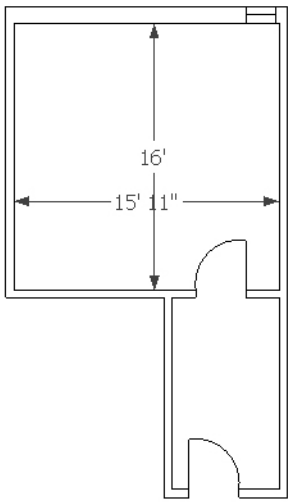

Suite 207, 314 RSF

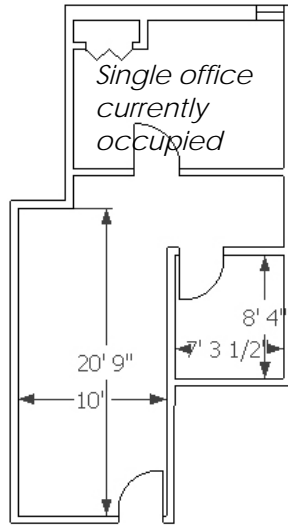

Suite 205, 318 RSF

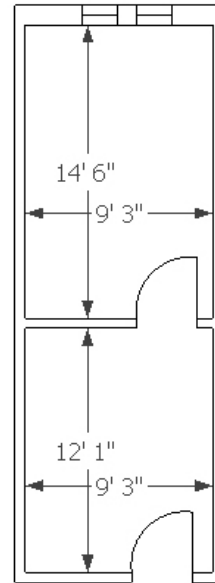

Suite 227, 323 RSF

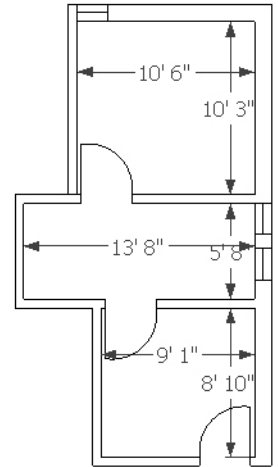

Suite 214, 600 RSF

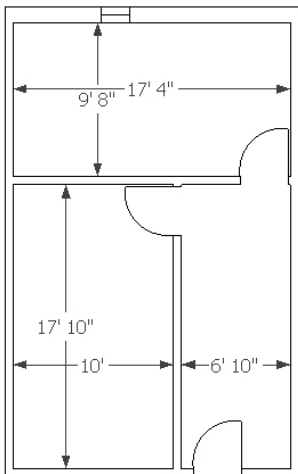

Suite 220, 955 RSF

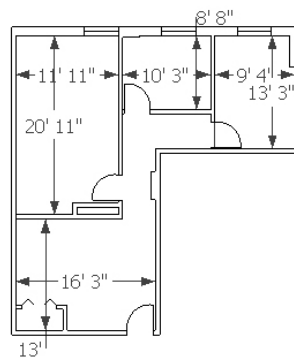

Suite 221, 1,036 RSF

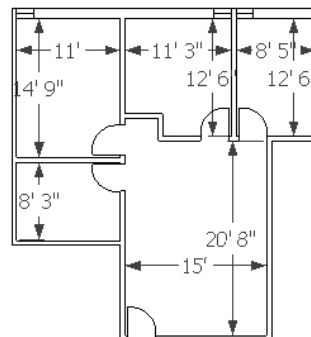

2,590 SF Warehouse

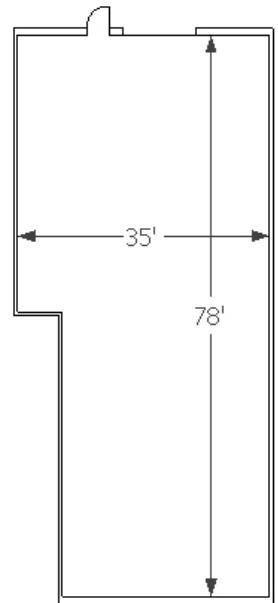

For more information call:
Peter Kordonowy

952.556.5151

or visit our website at:

www.summerhillcommercial.com